

Diffuse
M30x1,5
Sn = 2000 mm

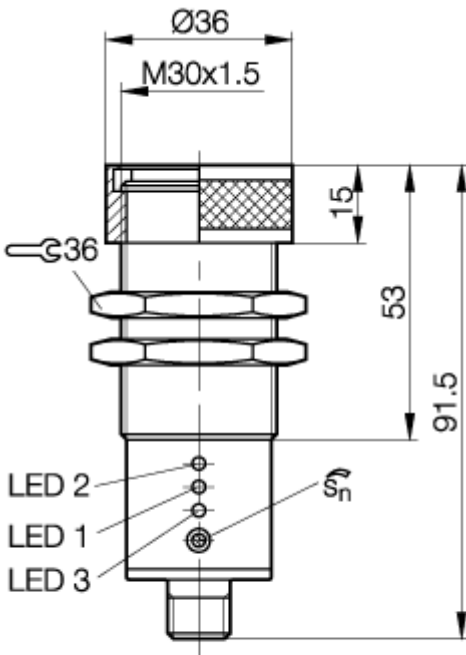

PX0226

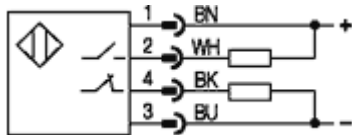

If not differently indicated,
all values by IEC 947-5-2 (DIN EN60947-5-2)

Sensing distance measured with :
Kodak white card 200mm x 200mm, 90% reflection
Specifications subject to change

Balluff GmbH
Postfach 1160
73761 Neuhausen
Telefon (07158) 173-0
Telefax (07158) 5010

Common Data

Sensortype	Diffuse
Switching frequency	100 Hz
Rated operating distance Sn	mm 2000
asured operating distance Sa	mm adjustable
Hysteresis	< 10%
Indication supply voltage	yes, green LED
Indication switching element	yes, yellow LED
Indication special function	Contamination Indicator, red LED
Ambient temperature	°C -20...+60°C
On/Off-delay	< 5ms
Light	Infrared
Sensitivity adjustment	18 turn Poti
Blind zone / min reflectore distance	1 mm
Permissable ambient light	lux 1000

Mechanical Data

Measurements BxHxT or DxT	mm	M30x91,5
Shock test (EN 60068-2-27)		Halfsinus, 30gn, 11ms
Vibration test (EN 60068-2-6)		10...55Hz, 1,5mm Amplitude 3x2h
Housing material		nickel plated brass
Material of sensing face		Glass
Degree of protection	IP	IP65
Connection		Connector S4 (M12)
Weight		230g

Electric Data

Current	DC
Switching function	normally-open/normally-closed
Output	PNP/NPN
Rated operational voltage Ue	V 24V
Rated operational current Ie	mA <200mA
Supply voltage	V 10-30V
Ripple	% max. 10% from UB
Voltage drop	V <2,4V
Short protection	yes
Protectde against polarity rev	yes
Rated Insulation voltage	75VDC
max. load capacity	1µF

21.01.2004 / Online-Information