

Accessories
BOS 21-HS-1
Mounting system



Common Data

Application

for Optosensors
series BOS 21M

Mechanical Data

Measurements BxHxT or DxT mm 50 x max.210 x
max.48

Mounting

screws

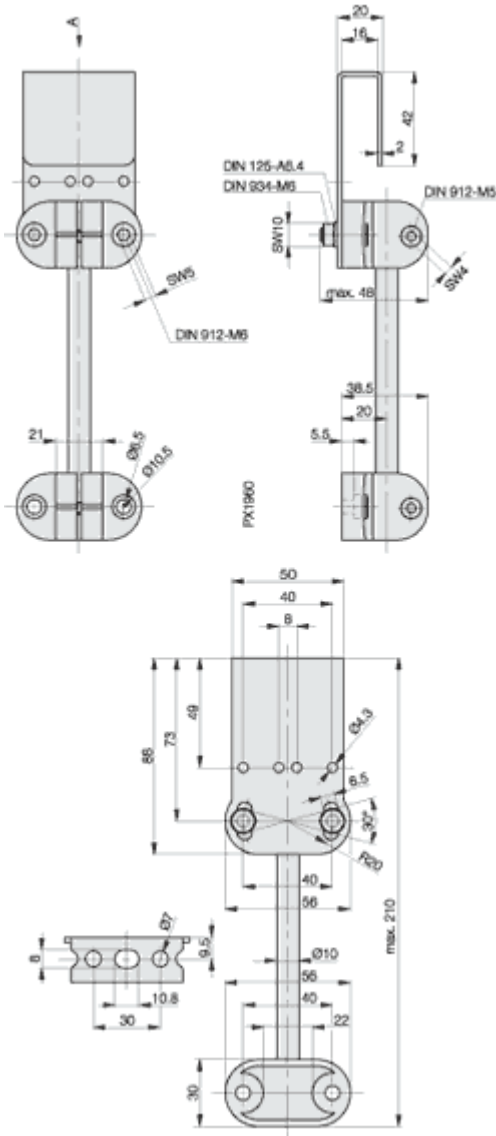

If not differently indicated,
all values by IEC 947-5-2 (DIN EN60947-5-2)
Specifications subject to change

Balluff GmbH
Postfach 1160
73761 Neuhausen
Telefon (07158) 173-0
Telefax (07158) 5010

02.07.2004 / Online-
Productinformation

BALLUFF

