

Inductive sensor Ni35-CP40-VP4X2

TURCK

Industrial
Automation

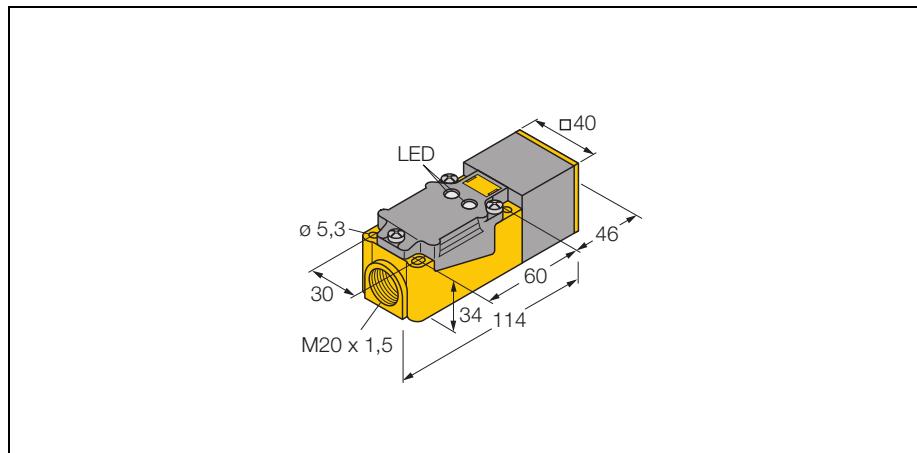

- rectangular, height 40 mm
- variable orientation of active face in 9 directions
- Plastic, PBT-GF30-V0
- 4-wire DC, 10...65 VDC
- change-over, pnp output
- Terminal chamber

Wiring diagram

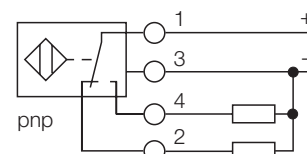

Functional principle

Inductive sensors are designed for wear-free and non-contact detection of metal objects. For this purpose they use a high-frequency electro-magnetic AC field that interacts with the target. Concerning inductive sensors, this field is generated by an LC resonant circuit with a ferrite core coil.

Type	Ni35-CP40-VP4X2
Ident-No.	15694
Rated operating distance Sn	35 mm
Mounting condition	non-flush
Assured sensing range	(0,81 x Sn) mm
Correction factors	St37 = 1, V2A ~ 0.7, Ms ~ 0.4, Al ~ 0.3
Repeatability	2 %
Temperature drift	± 10 %
Hysteresis	3... 15 %
Ambient temperature	-25...+ 70 °C
Operating voltage	10... 65VDC
Residual ripple	10 % U _{SS}
DC rated operational current	200 mA
No-load current I ₀	15 mA
Residual current	0.1 mA
Rated insulation voltage	0.5 kV
Short-circuit protection	yes / cyclic
Voltage drop at I _e	1.8V
Wire breakage / Reverse polarity protection	yes / complete
Output function	4-wire, change-over, pnp
Switching frequency	0.15 kHz
Housing	rectangular, CP40
Dimensions	114 x 40 x 40 mm variable orientation of active face in 9 directions
Housing material	plastic, PBT-GF30-V0, black
Material active face	plastic, PBT-GF30-V0, yellow
Connection	Terminal chamber
Clamping ability	2.5mm ²
Vibration resistance	55 Hz (1 mm)
Shock resistance	30g (11 ms)
Degree of protection	IP67
Operating voltage display	LED green
Display switch state	LED yellow

**Inductive sensor
Ni35-CP40-VP4X2**

Mounting instructions	minimum distances
Distance D	4,5 x B
Distance W	3 x Sn
Distance S	1,5 x B
Distance G	6 x Sn
Distance N	1 x B

Width of the active face B 40 mm

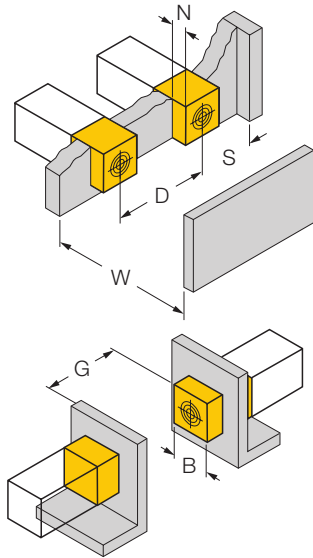

Inductive sensor Ni35-CP40-VP4X2

TURCK

Industrial
Automation

Accessories

Type code	Ident-No.	Short text	Dimension drawing
STRM M20X1,5 SCHWARZ	6965902	cable glands M20 x 1,5	
JS 025/037	69429	mounting rail; material: VA 1.4301	
BSS-CP40	6901318	fixing clamp; material: polypropylene	